



SQN2130 1ST PHY AND MAC ASIC

- WIMAX FORUM™ WAVE 2 READY
- 2X2 MIMO
- TDD AND FDD
- FLEXIBLE AND COST EFFECTIVE FOR ANY SIZE BASE STATIONS
- LOW COST FOR FEMTOCELLS WITH NO COMPROMISE ON FEATURES
- STANDARD INTERFACE TO ASN GATEWAY



SQN2130

A FIRST PHY & MAC ASIC ON THE MARKET

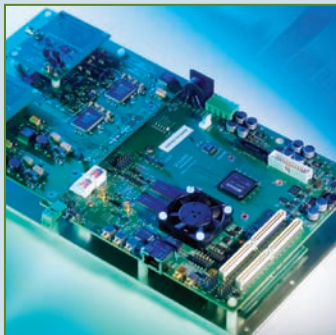

BASE STATION REFERENCE DESIGN

Sequans' SQN2130 is a base station chip fully compliant with the IEEE 802.16e-2005 standard. It integrates all MAC and PHY features required for WiMAX Forum Wave 2 certification and is delivered with Sequans Software Solution, S-Cube, a comprehensive and flexible software package.

THE SOLUTION FOR EVERY APPLICATION

The SQN2130 is a flexible, low cost, high performance solution allowing manufacturers to build an entire range of WiMAX base stations, from access points (femtocells) to pico/micro and multi-sector macro base stations for fixed/nomadic and mobile applications.

- **Flexible, total solution**

SQN2130 is a highly integrated, MAC & PHY baseband solution. The combination of small size, low-cost, and low-power consumption, provides maximum flexibility to build any size base station, in TDD or FDD mode, with no compromise in features or functionality. The SQN 2130 interfaces with a range of RF solutions from Sequans partners, from low power RFIC solutions for femtocell and pico base stations, to high power remote RF heads with OBSAI interface. SQN2130-based products are easily integrated into existing deployed networks via standard interface to ASN gateway.

- **Ideal for pico base stations and femtocells**

The SQN2130's level of integration and built-in dynamic power optimization techniques are ideal for base stations with strong constraints on cost, power consumption, and footprint. A low cost host/network processor may be used to run Sequans Software Solution, S-Cube, along with the customer's applications.

- **Serves large number of users**

The SQN2130 can support several thousand subscriber stations and operates at the full line rate, translating to throughput of more than 35 Mbps, even with small packet sizes. In addition to advanced MIMO, the SQN2130 supports Hybrid-ARQ Category 4.

PRODUCT CHARACTERISTICS

Physical

- 23 mm x 23 mm, PBGA , ROHS compliant
- -40°C to + 85°C operating conditions
- Power consumption: < 2W in MIMO mode

Throughput

- > 35 Mbps even with 64 bytes packet
- Thousands of users

PHY

- S-OFDMA PHY with 512 and 1024 point FFT
- Adaptive modulation: QPSK, 16-QAM and 64-QAM on uplink and downlink
- 2Tx/2Rx
- Multiple antenna support (downlink spatial multiplexing—MIMO Matrix B, uplink MRC-2, and uplink and downlink STC-2—MIMO Matrix A)
- TDD and FDD
- H-ARQ Cat 1-4
- Downlink and uplink MAP formats (normal, compressed, and sub DL-UL-MAP)
- DFS
- Fast feedback channel
- Fast scanning and ranging
- Power control: open and closed loop

MAC

- Layer-2 packet forwarding
- PKMv2 privacy protocol
- Real time and non real time services
- ARQ
- PHS
- Advanced QoS features (weighted fair queuing, traffic shaping, congestion management, random early detection—RED, and hierarchical QoS)
- Handover (mobile station and base station initiated and handover optimization)
- MBS with multiple base stations
- Sleep and idle modes

Data interfaces

- MII

RF and other interfaces

- 12bit RF digital IQ
- Generic and programmable RF control interface
- Master/slave PCI bus interface
- 1 PPS/10 MHz clock reference for frame synchronization between base stations

• Full-featured MAC layer

Sequans' extremely efficient MAC implementation is strategically partitioned between hardware and software to maximize throughput and minimize power consumption. Complete support for mobility is provided, in particular for optimised handover, sleep mode, and idle mode.

• Rich, flexible software

Sequans Software Solution, S-Cube, comprises hardware drivers, MAC, and scheduling functions. The software is modular, with well-defined API, allowing manufacturers to reuse their existing software modules and expertise to differentiate their product offerings, while leveraging the performance and time-to-market advantages offered by Sequans Software Solution. S-Cube is common to both base station and mobile station solutions, providing a major advantage to those system vendors developing both ends of the link as it significantly reduces development time.

• Quick path to certification

Sequans early participation and involvement in all WiMAX Forum™ PlugFests and certification activities, along with its partnerships with the major PCT and RCT test equipment vendors, provides system vendors with a quick path to certification.

• Reference design

Sequans' SQN 2130-RD, is a complete reference design based on the SQN2130. It includes RF boards with drivers, a PowerPC mezzanine card, memory, power supply, and Ethernet PHY, as well as the MAC software modules and a user-friendly documentation.

The following figure demonstrates a typical channel card architecture to address one sector on one frequency assignment.

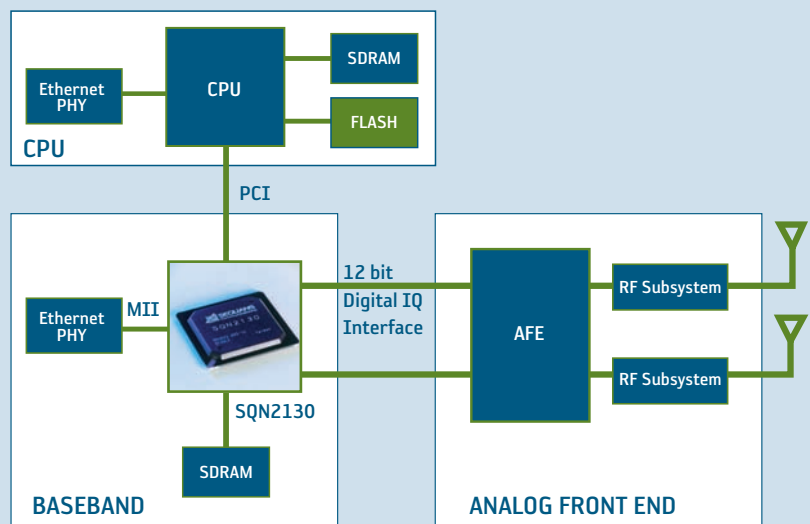

Sequans and Sequans Communications are trademarks or registered trademarks of Sequans Communications. All other products and brand names mentioned are trademarks or registered trademarks of their respective owners.

© Sequans Communications 2007
SQN2130FL07

